



Multiple Earthed Neutral (MEN) systems when more than one meter is used.

The MEN should always be maintained to the electrical installation, and should not be dependant upon the principle meter being intact. The MEN also needs to be accessible and cannot go on the ActewAGL unmetered neutral link since this link is sealed.

Reference Neutral

The drawing below (fig. 1) is the solution to maintaining an MEN to an electrical installation when multiple meters are used and a *reference neutral* is supplied to the meters.

Figure 1

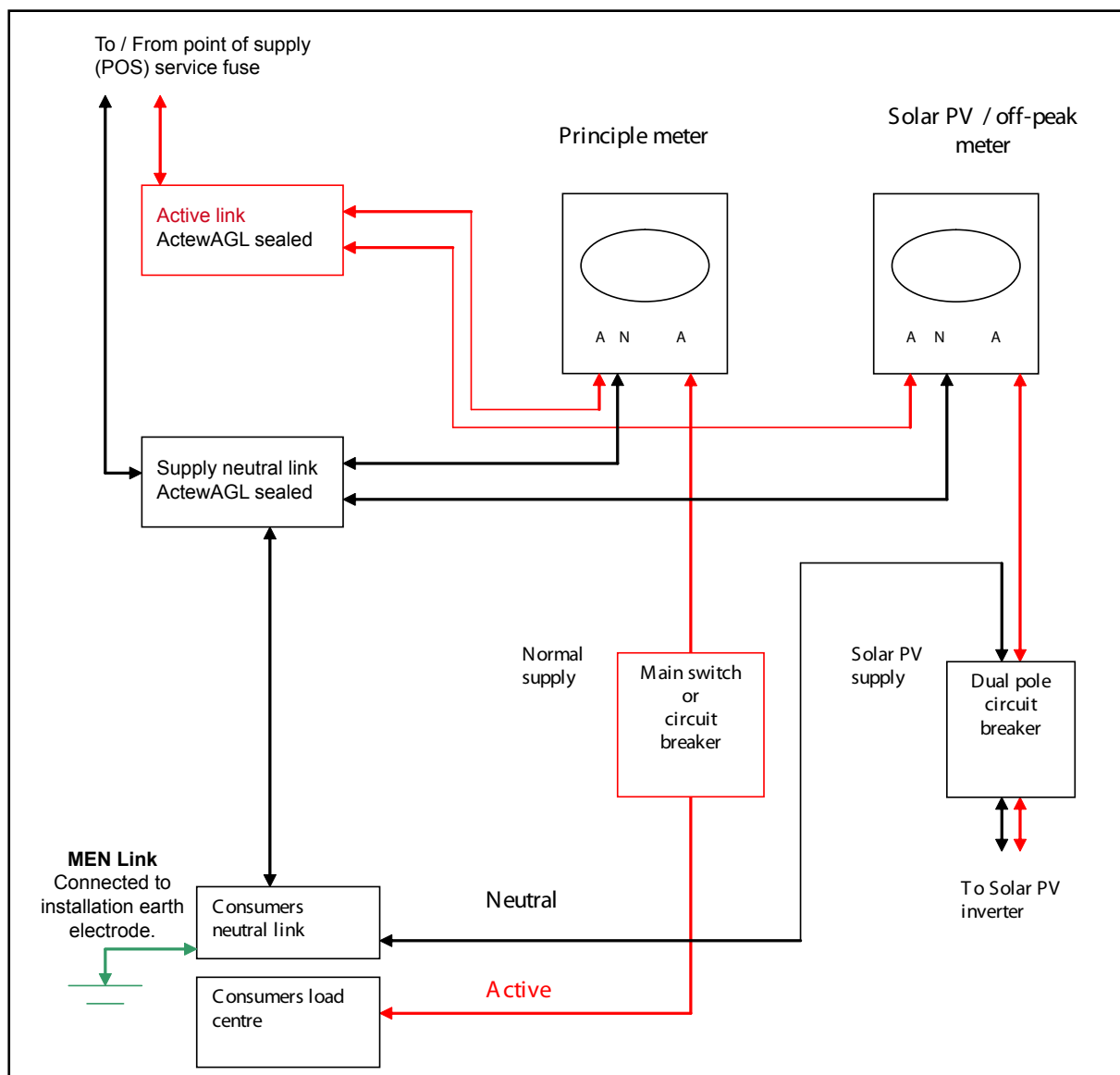

Full Neutral Load

The drawing below (fig. 2) is the solution to maintaining an MEN to an electrical installation when multiple meters are used and *full neutral load* is put through the principle meter.

Figure 2

